

# Hexagon Acoustic Ceiling Tile

TL-0215

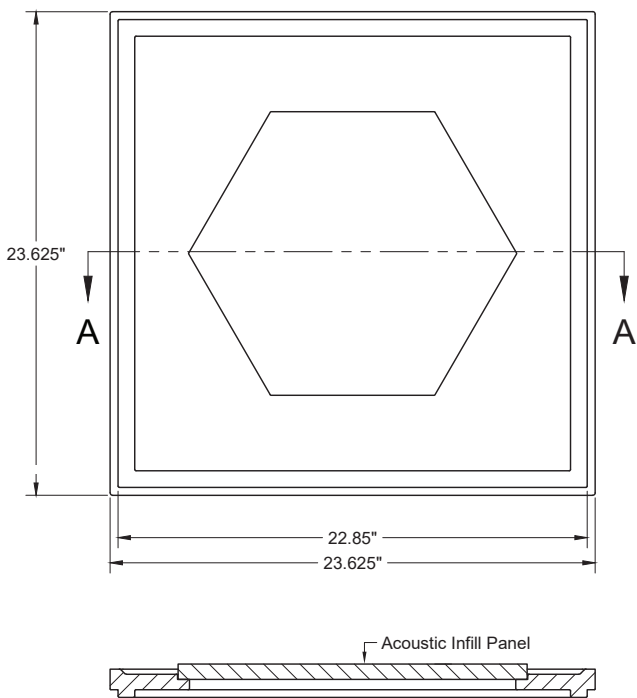

<b>NOMINAL SIZE:</b>	2' x 2'
<b>MATERIAL:</b>	Gypsum, glass fibers, and other non-combustible aggregates
<b>WEIGHT:</b>	9.65 lbs/tile
<b>STANDARD FINISH:</b>	White satin latex paint
<b>CUSTOM / FAUX FINISHES:</b>	Available upon request
<b>FIRE RATING:</b>	Class A, with zero smoke spread, zero flame spread, and zero fuel contribution
<b>INSTALLATION:</b>	Drop into any standard commercial 15/16 inch T-Bar suspension grid, consisting of pre-punched roll-formed steel with exposed flange surface
<b>EASY TO FIELD CUT:</b>	For sprinklers, recessed lights, pendants and vents.
<b>FACTORY CUT HOLES AND RADII FOR PERIMETERS:</b>	Inquire
<b>CUSTOM DESIGNS AVAILABLE:</b>	Inquire
<b>MADE IN USA:</b>	Handmade, one-at-a-time in Milwaukee, WI



SECTION A-A

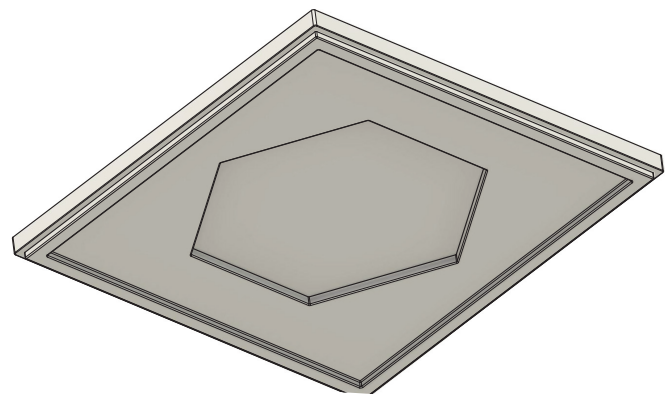

*Complete dimensions and .dwg file available upon request.*